

SEZIONE A-A

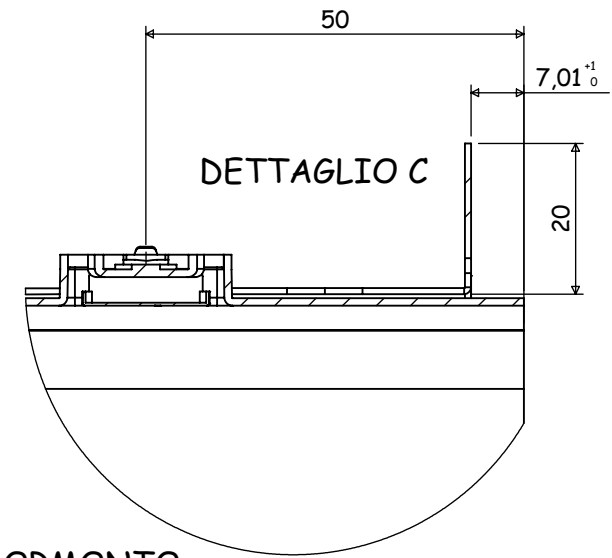

SORMONTO
BORDO
VASCA

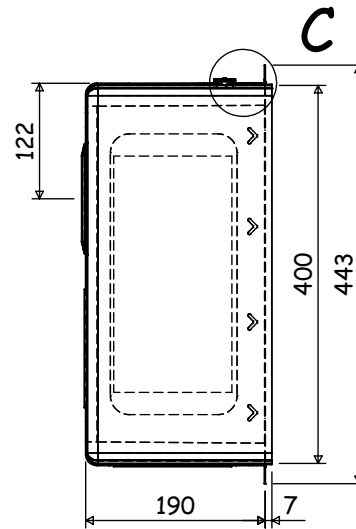
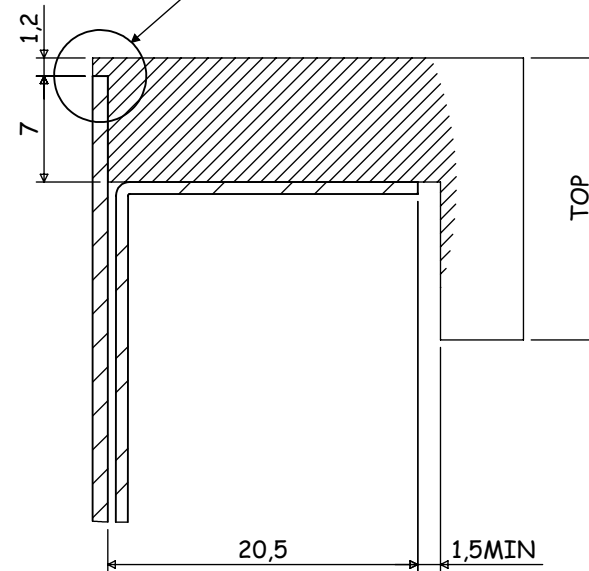
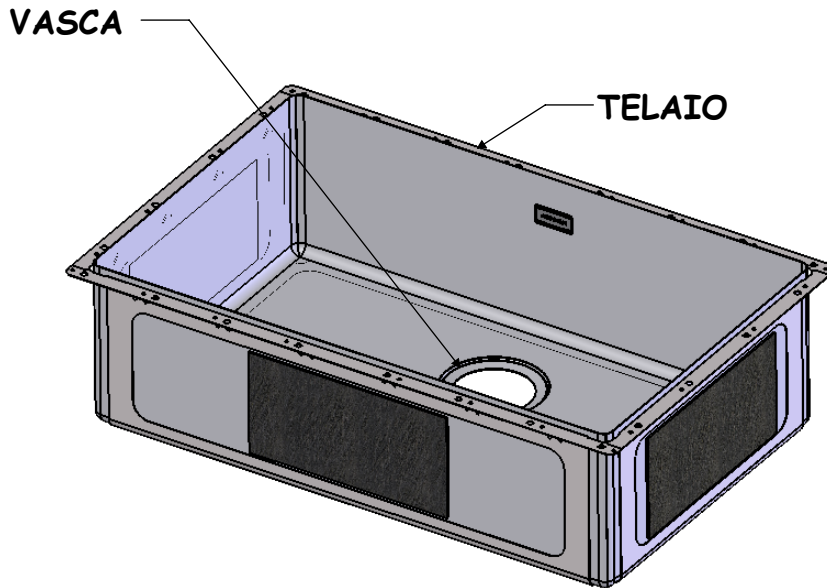

00008L65



CLIENTE:	ARTINOX	VS. RIFERIMENTO:	***	MATERIALE:	AISI 304 - 10/10	SCALA:	***	DISEGNATORE:	B.IGOR
DESCRIZIONE:	LAVELLO LINEA 65	NS. CONFERMA:	***	FINITURA:	SB1			DATA:	01/02/2023
Il disegno è di proprietà di Artinox S.p.a. è vietata la riproduzione o la divulgazione del contenuto senza autorizzazione scritta. Le quote senza tolleranza si riferiscono alla classe: - grossolana da 0,5 a 6 - media oltre 6 fino a 4000 UNI EN 22768-1:1996				CODICE:	***	31015 Conegliano (TV) Italy Tel.+39 0438 4531 Fax.+39 0438 453222 E-mail:domestic@artinox.com http://www.artinox.com			