

CLIENTE:	<b>ARTINOX</b>	VS. RIFERIMENTO:	<b>***</b>	MATERIALE:	<b>AISI 304 - 10/10</b>	SCALA:	<b>-</b>	DISEGNATORE:	<b>B.IGOR</b>
DESCRIZIONE:	<b>LAVELLO PLANUM XL81</b>	NS. CONFERMA:	<b>***</b>	FINITURA:	<b>S.B.1</b>			DATA:	<b>08/11/2022</b>
Il disegno è di proprietà di Artinox S.p.a. è vietata la riproduzione o la divulgazione del contenuto senza autorizzazione scritta. Le quote senza tolleranza si riferiscono alla classe: - grossolana da 0.5 a 6 - media oltre 6 fino a 4000 UNI EN 22768-1:1996				CODICE:	<b>***</b>	31015 Conegliano (TV) Italy Tel.+39 0438 4531 Fax.+39 0438 453222 E-mail:domestic@artinox.com http://www.artinox.com			

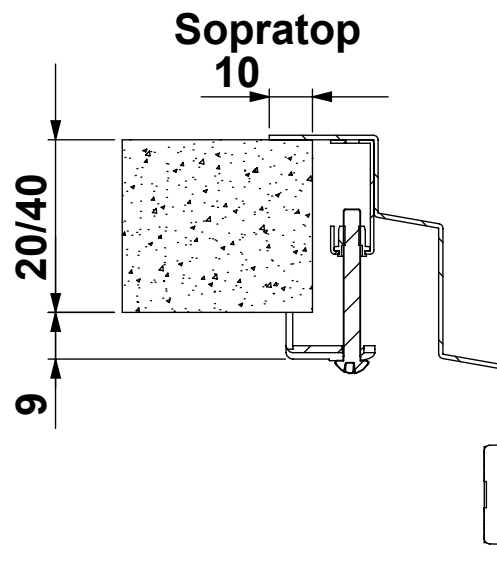

### Foro Sopratop

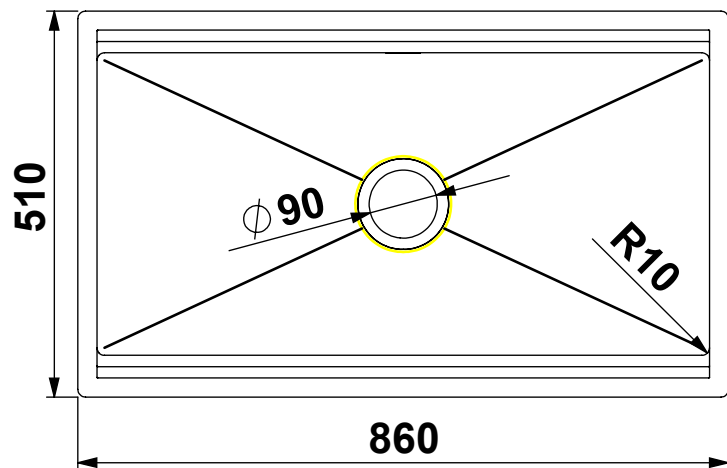
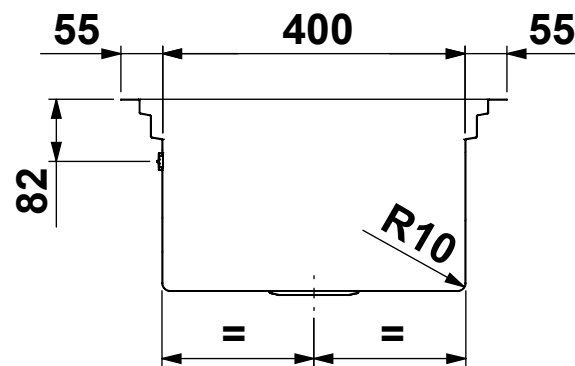
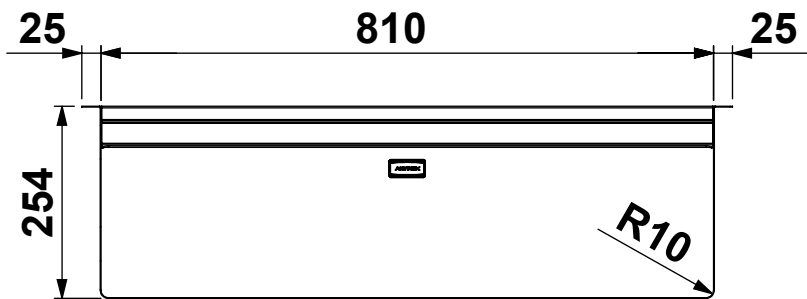
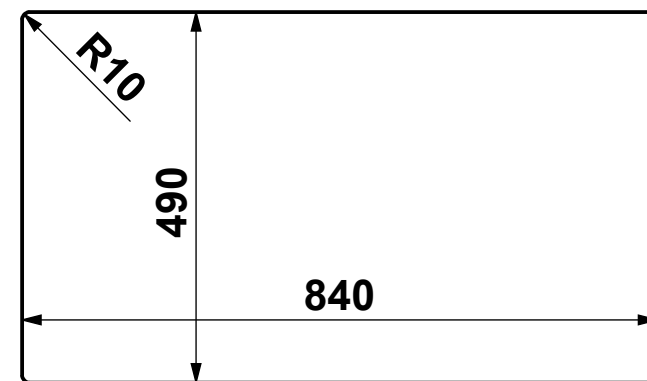

CLIENTE:	<b>ARTINOX</b>	VS. RIFERIMENTO:	<b>***</b>	MATERIALE:	<b>AISI 304 - 10/10</b>	SCALA:	<b>-</b>	DISEGNATORE:	<b>B.IGOR</b>
DESCRIZIONE:	<b>LAVELLO PLANUM XL81</b>	NS. CONFERMA:	<b>***</b>	FINITURA:	<b>S.B.1</b>			DATA:	<b>08/11/2022</b>
Il disegno é di proprietà di Artinox S.p.a. è vietata la riproduzione o la divulgazione del contenuto senza autorizzazione scritta. Le quote senza tolleranza si riferiscono alla classe: - grossolana da 0.5 a 6 - media oltre 6 fino a 4000 UNI EN 22768-1:1996				CODICE:	<b>***</b>	31015 Conegliano (TV) Italy Tel.+39 0438 4531 Fax.+39 0438 453222 E-mail:domestic@artinox.com http://www.artinox.com			